



Improve your Indoor Air Quality with UVC Air Purification

Ensure that you and your family are breathing clean air with the power of UVC technology. Simple to use and easy to install, this system mounts onto your existing forced air furnace.



10 YEAR WARRANTY

Effectively Purifies up to **3500 Sq. Ft.**

PRODUCT FEATURES

- Lamps produce no ozone
- Energy efficient electronic ballast
- Safety feature designed to prevent accidental exposure to UVC light
- Built-in lamp replacement indicator (Replace lamp once a year for optimal performance)
- Safely purifies home up to 3500 sq. ft.
- Installs in less than 15 minutes



Compact and easy to install



Provides clean fresh air for the entire home



Kills germs that cause colds and flus



Alleviates allergies and asthma symptoms

**OPTIONAL INSTALLATION LOCATIONS
ON FORCED AIR FURNACE**

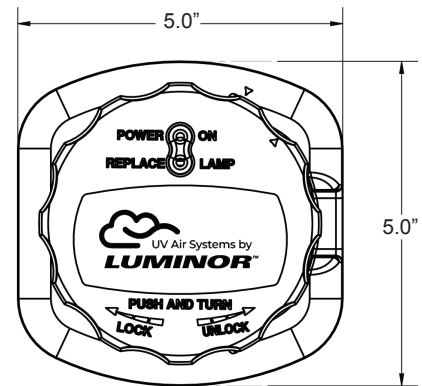
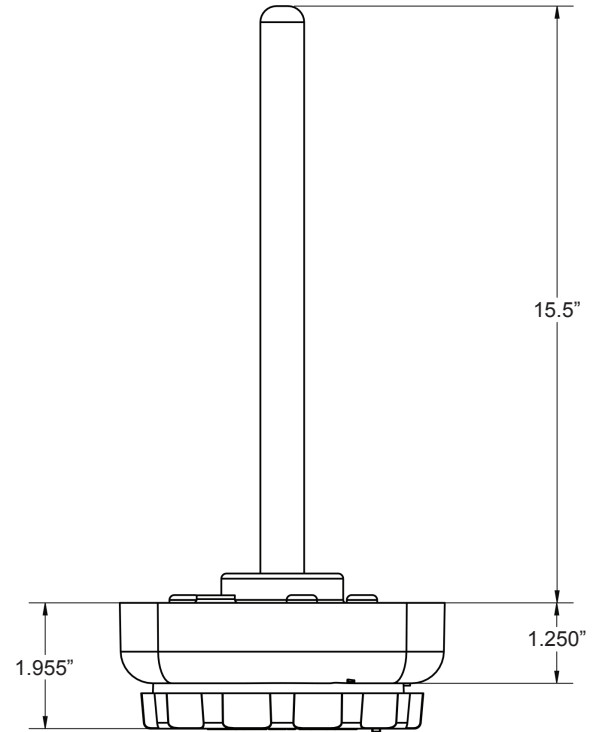
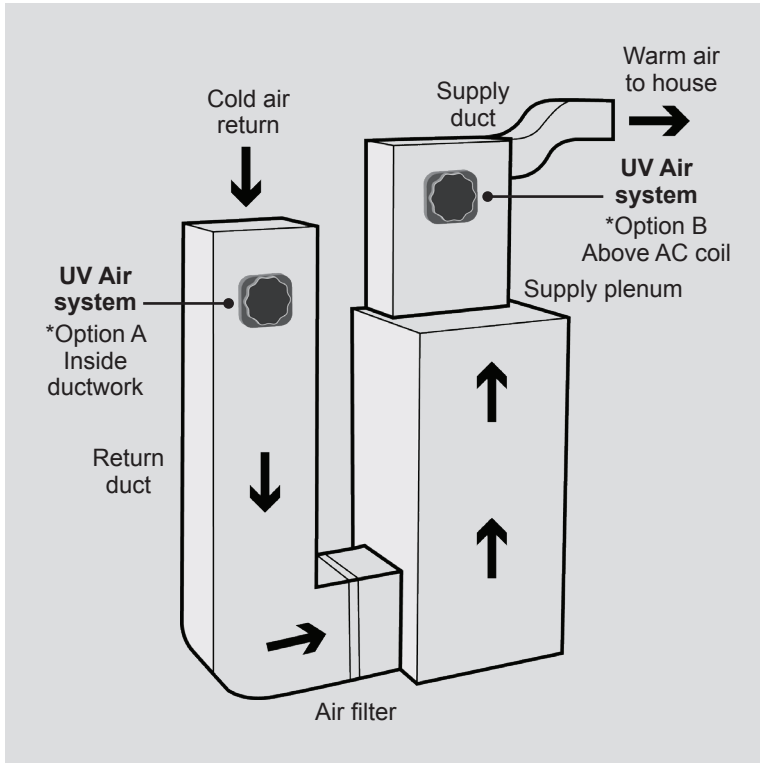

| PRODUCT SPECIFICATIONS | UVAIR-01 |
|-----------------------------|------------------|
| INPUT SUPPLY VOLTAGE | 108-132V |
| INPUT SUPPLY FREQUENCY | 60 Hz |
| POWER (WATTS) | 36 |
| PRIMARY AMPERES | 0.55A |
| OPERATING TEMPERATURE | -5 °C to 75 °C |
| OPERATING RELATIVE HUMIDITY | 90% |
| POWERHEAD DIMENSIONS | 5" (w) x 5" (h) |
| REPLACEMENT LAMP | UVAIR-RL1 |
| LAMP CHANGE REMINDER | YES |
| LAMP OUT INDICATOR | YES |
| SHIPPING WEIGHT | 1.0 kg (2.2 lbs) |

MANUFACTURER'S WARRANTY

Ten (10) year Limited Warranty on the powerhead, from the date of original purchase, or installation.

See website for LUMINOR's complete warranty document including conditions and exclusions.



EPA Establishment
#088776-CAN-001



LUMINOR Environmental Inc.
80 Southgate Drive, Unit 4
Guelph, Ontario, CANADA N1G 4P5
Phone: (519) 837-3800
Toll Free: (855) 837-3801
info@luminoruv.com
www.luminoruv.com



Watertiger
Tame Your Water

